

Overview

Project Objective: Develop a model of a **low-cost wireless sensor network** for embedded **monitoring on naval equipment** and infrastructural components. Sensor types shall be of a small form factor, consisting of an **accelerometer, pressure transducer, fluid flow, current, voltage, and temperature sensor**.
Project Scope: RF communication, **200ft distance** of up to 6 standard 4-20mA loop-based RTD sensors. Include sensor readings. Storage 32sec samples at bitrate of **~1 Mbit/sec (10kHz @ 16bit x 6 channels)**.

Milestone:

- Establish Wireless Communication
- Support RF Communication up to 200 ft Distance
- Implement 6 Sensors & Calibration
- Data Validation & Store Data at 1 Mbit/sec
- Develop Event Trigger and Battery System
- Data Security

Hardware

- Processing Components:
 - NUCLEO-STM32WB55RG
 - Raspberry Pi 3B
- Battery System:
 - 2 Cell Battery Management System (BMS) Module
 - 3.7V Li-ion Battery Fuel Gauge Module (ModelGauge)
 - Low Dropout Step-Down Linear Voltage Regulator Module
- Sensor:
 - K-Type Surface Thermocouple
 - Hall Effect Flow Sensor
 - Voltage Divider Voltage Sensor
 - Hall Effect AC Current Clamp
 - Capacitance Pressure Sensor
 - NCD 3-axis Accelerometer + Wireless USB Modem
 - Piezoelectric Trigger System

Software

- STM32Cube Hardware Abstraction Layer
- OpenThread Border Router & Commissioner
- Raspberry Pi OS

Thread Protocol

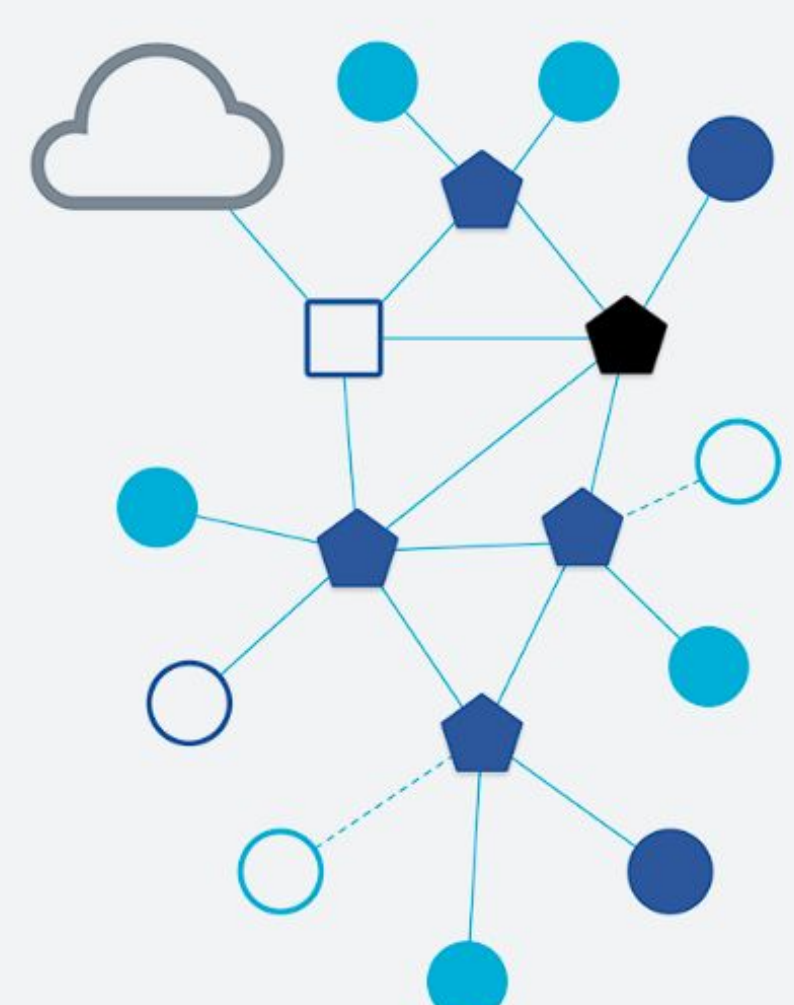

Features

OpenThread implements all Thread networking layers (IPv6, 6LoWPAN, IEEE 802.15.4 with MAC security, Mesh Link Establishment, Mesh Routing) and device roles, as well as Border Router support.

APPLICATION SERVICES

- IPv6 configuration and raw data interface
- UDP sockets
- CoAP client and server
- DHCPv6 client and server
- DNSv6 client

CO-PROCESSOR SUPPORT

- Spinel, a general purpose Co-Processor protocol
- OT Daemon, a user-space Radio Co-Processor network interface driver/daemon
- Sniffer support via Spinel nodes

ENHANCED FEATURES

- Child Supervision
- Inform Previous Parent on Reattach
- Jam Detection
- Periodic Parent Search

BORDER ROUTER

- Bidirectional IPv6 reachability between Thread and Ethernet/Wi-Fi
- Bidirectional DNS-based service discovery between Thread and Ethernet/Wi-Fi
- Extending Thread mesh over Ethernet/Wi-Fi links

Implementation

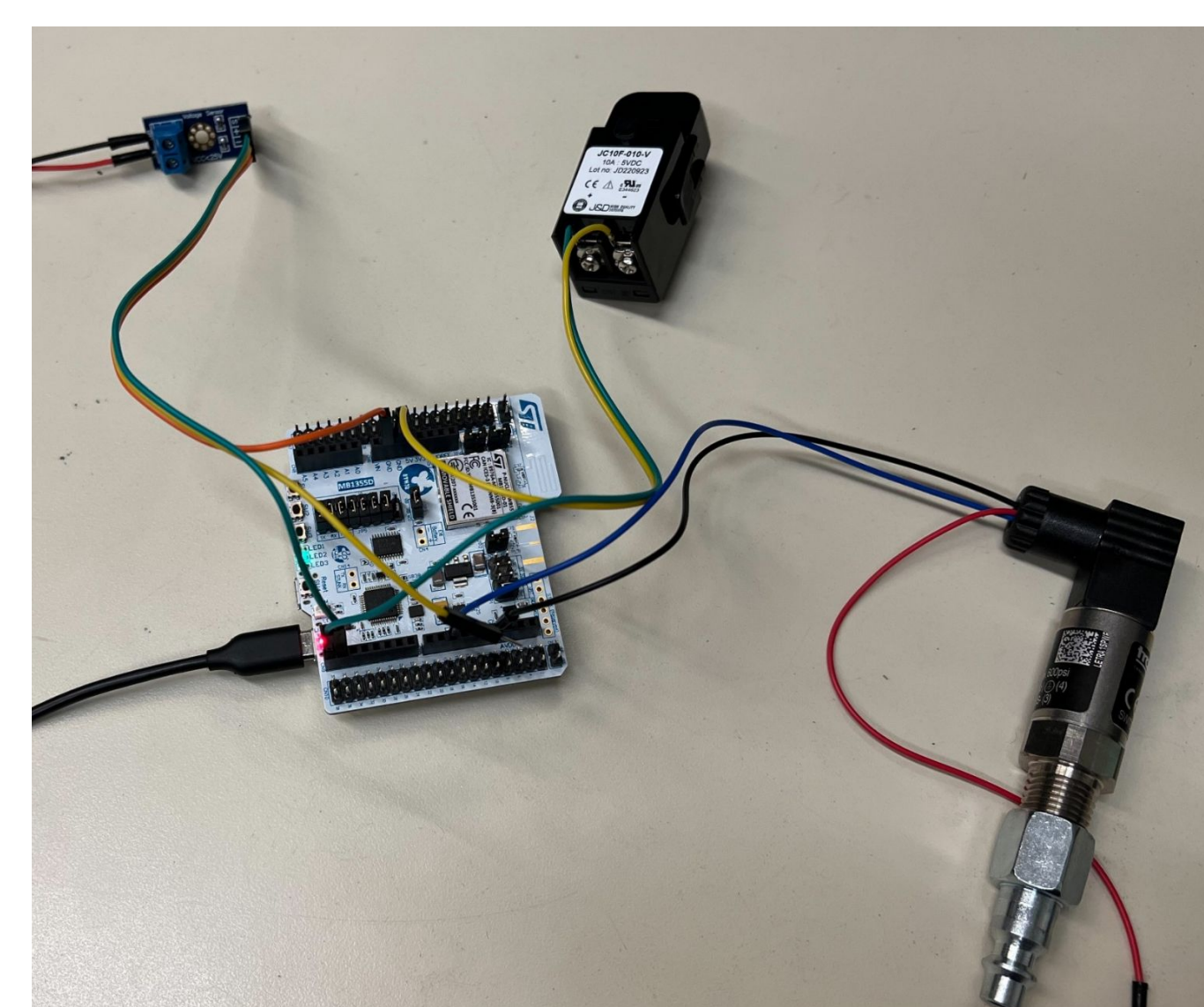
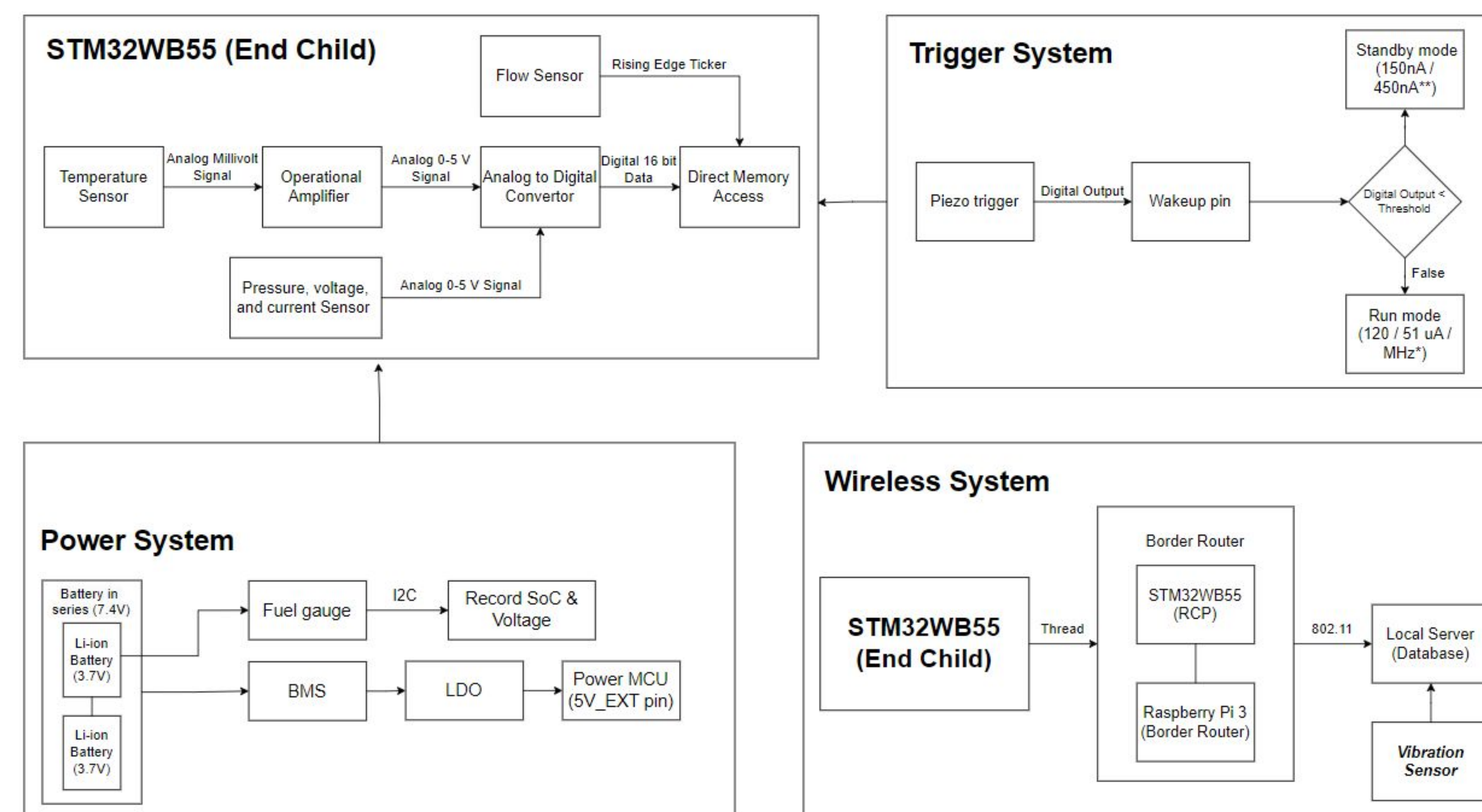

STM32WB55 (End Child)

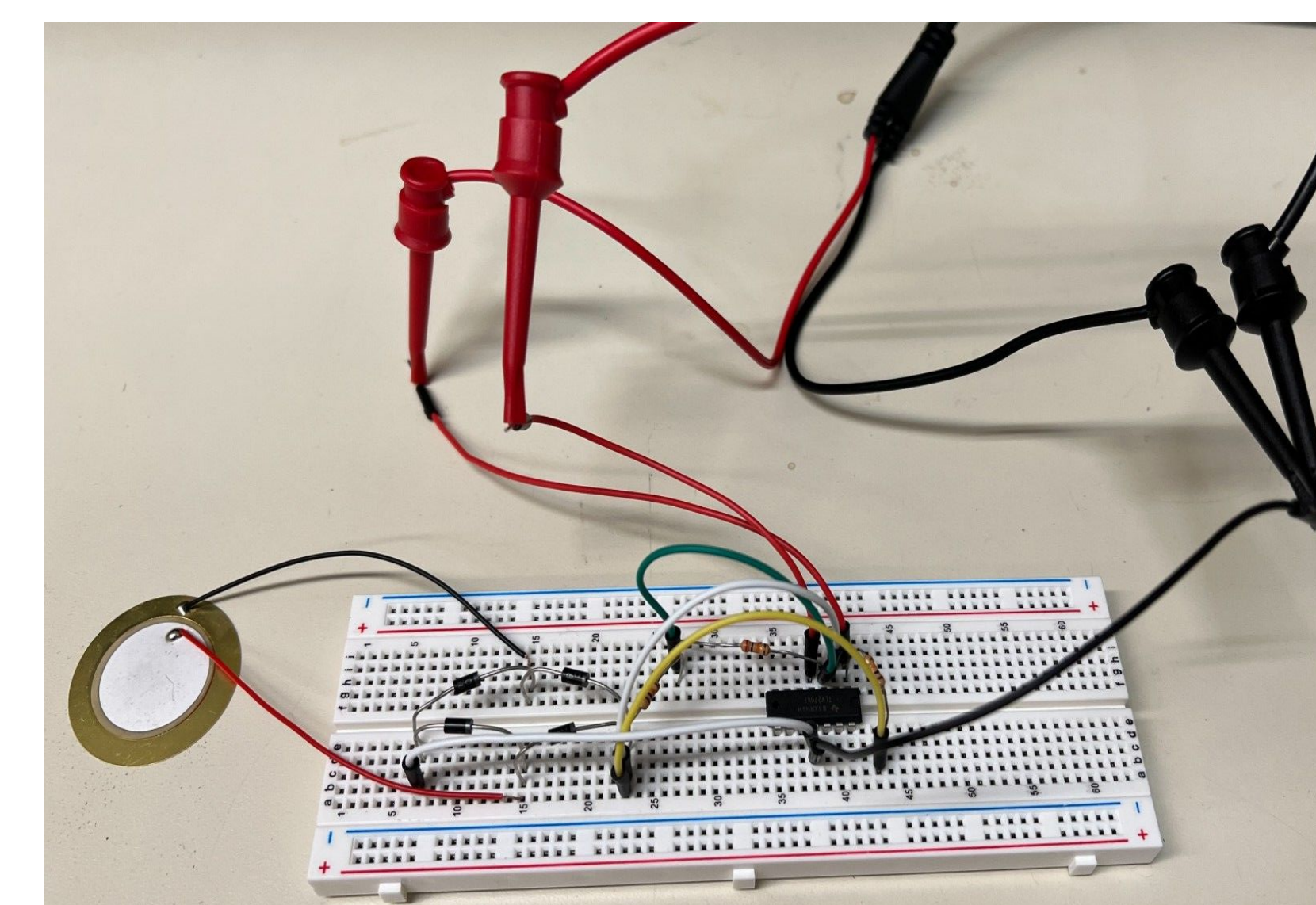

Trigger system

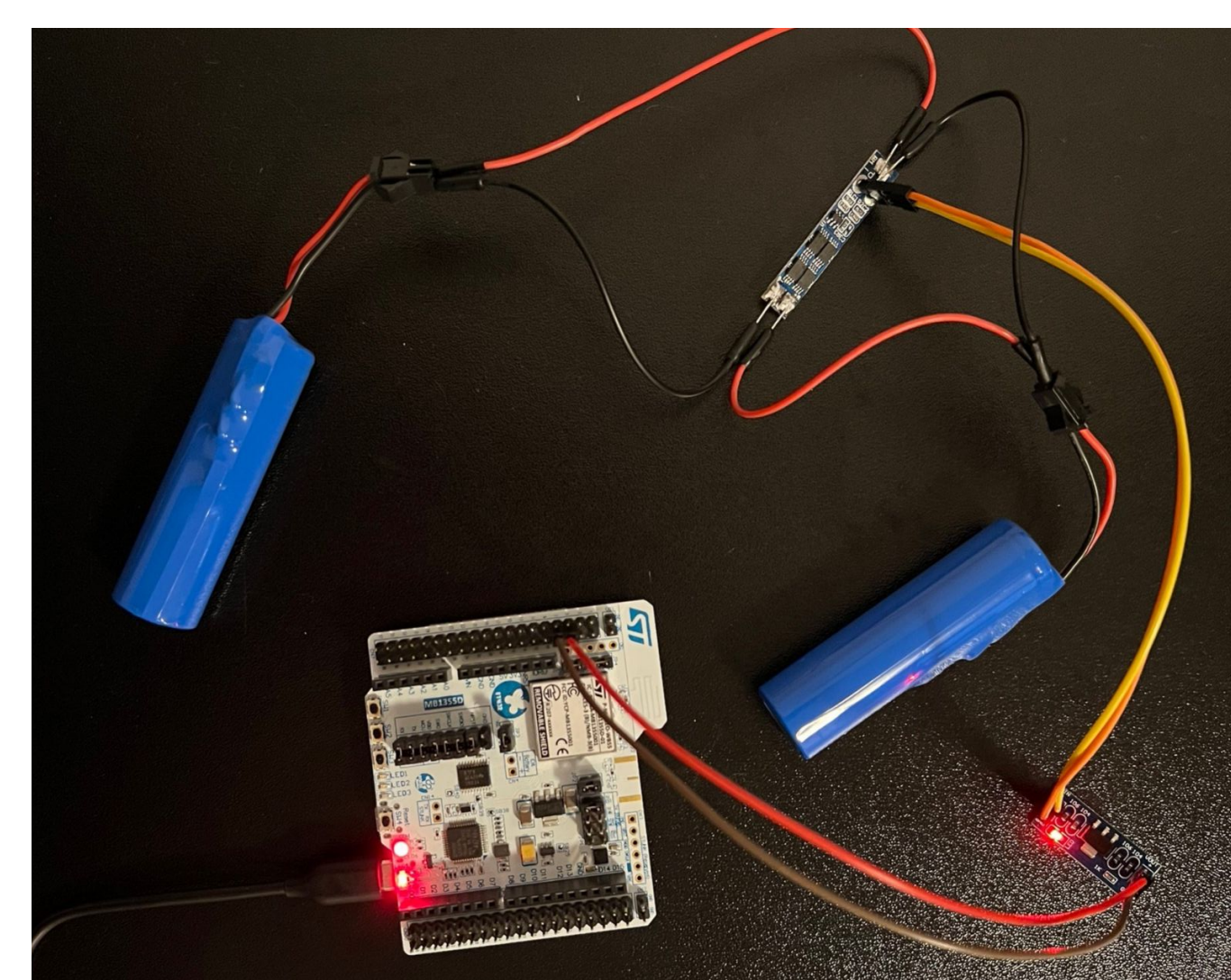

Power system

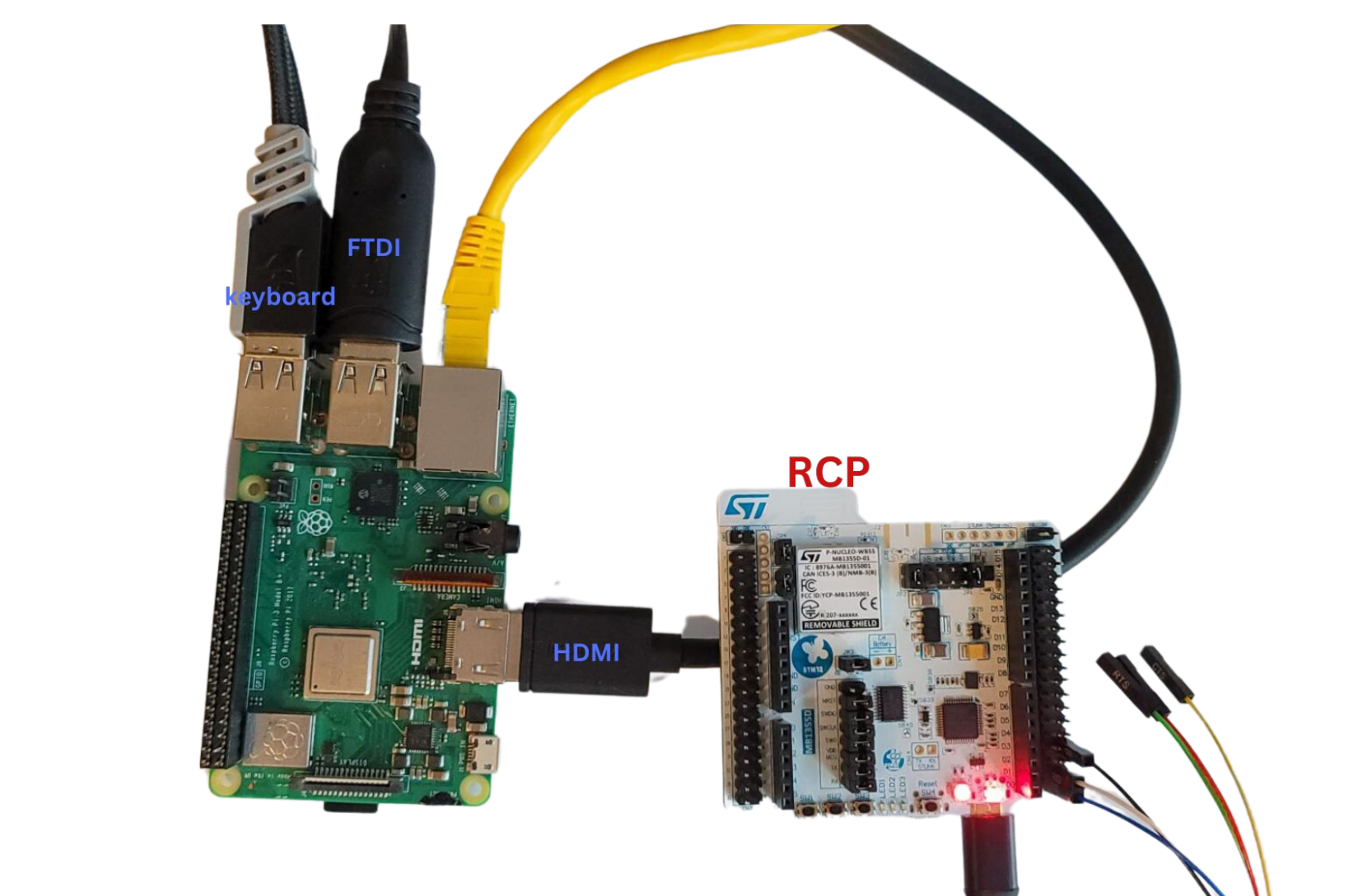

Wireless system

Test Results & Conclusion

Sensors:

- Thermocouple, pressure transducer, voltage, and current can all work under required conditions with accuracy of $\pm 1\%$.
- Accelerometer operates with the sampling rate of 5kHz.
- The calibrated sensor data undergoes processing via a high-performance, multi-channel 16-bit ADC with DMA functionality.

Network:

- Established a robust Thread network between the Raspberry Pi border router and STM32 end device for communication and connectivity.
- The end child node instantaneously transmits data to the border router through UDP connection.

Trigger system:

- To optimize power efficiency, we have incorporated a low power mode that leverages a wakeup piezo trigger system.

Power system:

- The Battery Management System (BMS) ensures the safety of the Li-ion battery as well as regulates the voltage through the Low Dropout (LDO) mechanism to power the MCU.
- Incorporates real-time monitoring with fuel gauge that directly linked to the battery to accurately track the battery percentage for enhanced usability and efficiency.

Future works

- Sensors : Implementation of a more accurate flow sensor.
- Battery : Consider implementing a double cell fuel gauge for more precise reading of battery level.
- Hardware Network : Adopt Aruba network system to create local, self-contained, and secure communication.
- Software Implementation :
 - Optimize data transfer methodology
 - Change communication protocol from UDP to CoAP or TCP
 - Improve data encryption method
 - Gain access and utilize STM32's non-public documentation

Acknowledgments

- Faculty: Prof. Tai Chen
- Lab Resources:
 - UW Aeronautics and Astronautics Lab (Thijs Masmeyer)
 - UW Power Lab (Daniel Kirschen)
- Industry Experts: Luna Labs (Kevin Farinholt and David Alibakhshi)